



Hollow cone
nozzles

Hollow cone nozzles

- 
- Absorption
 - Chemical process engineering
 - Cooling
 - Disinfection
 - Desuperheating
 - Dust control
 - Fire protection
 - Foam destruction
 - Gas treatment
 - Humidification of air
 - Humidification of goods
 - Humidification of textiles
 - Oil spraying
 - Protection of storage tanks
 - Spraying onto filters
 - Spraying over germinating boxes
 - Water recooling
 - and many others...



Hollow cone nozzles

Axial-flow hollow cone nozzles

Wherever a fine, uniform hollow cone spray is needed, e.g. for cooling and cleaning of gas, absorption processes, dust control, product dampening, oil spraying and air humidifying, axial-flow hollow cone nozzles have proved very efficient. The spiral grooves in the swirl inserts ensure an efficient whirling of the liquid. As a result, the contact surface of the atomized liquid is significantly increased within a remarkably narrow droplet spectrum. This creates extraordinarily favourable conditions for mass transfer.

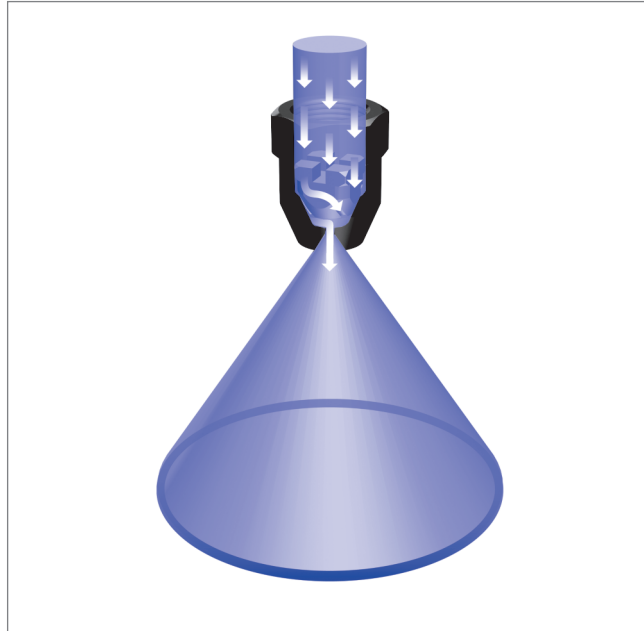

- Finest drop particles
- Narrowest free cross-sections
- Maximum spray angle: 90°

Tangential-flow hollow cone nozzles

Tangential-flow hollow cone nozzles provide a very uniform hollow cone spray thanks to a particular flow geometry. Liquid is put into rotation by an eccentric arranged liquid inlet. Thereby a very uniform liquid distribution is achieved with spray angles up to 130°. Tangential-flow hollow cone nozzles are of a self-cleaning design, offering a high operational safety, even at rather poor water conditions. Typical applications for tangential-flow hollow cone nozzles are: air humidification in air conditioning systems or gas cleaning in chemical and environmental engineering installations.



- Coarser droplets than axial-flow hollow cone nozzles
- Large narrowest free cross-sections
- Wide spray angles up to 130°
- Self-cleaning, non-clogging

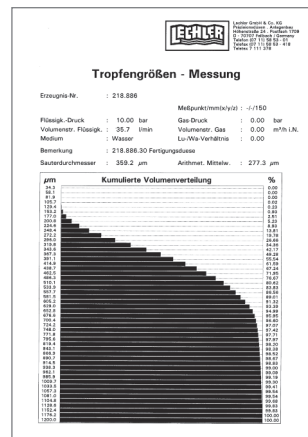
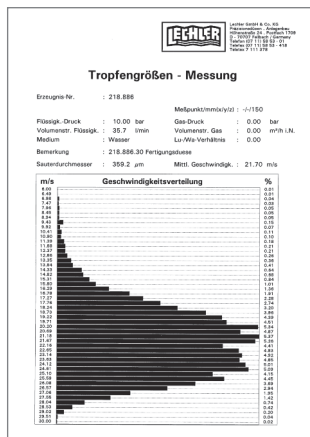







Number/frequency distribution chart

Cumulated volume distribution chart









Hollow cone nozzles

Axial-flow hollow cone nozzles	Series		\dot{V} [l/min] at $p = 2$ bar	Connection	Application/ Design	Page
	212	60° 80°	0.015 – 0.46 (at $p = 7$ bar)	1/4 BSPT 1/4 BSPP	Disinfection, humidification of air, spraying over germinating boxes, product dampening, humidification of textiles, oil spraying, absorption. Extremely fine, fog-like hollow cone spray.	2.5
	214	60° 80°	0.08 – 0.32	1/8 BSPP	Cooling and cleaning of air and gas, dust control, spraying onto filters, spray drying, desuperheating	2.6
	216	60° 90°	0.40 – 8.50	3/8 BSPP		
	2TR	80°	0.16 – 1.57	Assembly with 3/8" retaining nut	Humidification of air, cooling and cleaning of gases, dust control, spraying onto filters. Fine, uniform hollow cone spray.	2.7
Tangential-flow hollow cone nozzles	Series		\dot{V} [l/min] at $p = 2$ bar	Connection	Application/ Design	Page
	302	60° 80° 90° 130°	0.40 – 25.00	3/8 BSPP	Humidification of air in air washers, dust control, spraying onto filters, foam control, cooling. Non-clogging nozzle design, without swirl insert.	2.8 2.9



Hollow cone nozzles

Tangential-flow hollow cone nozzles	Series		\dot{V} [l/min] at $p = 2$ bar	Connection	Application/ Design	Page
	308	90°	0.63 – 3.15	3/8 BSPP	Foam destruction, dust control. Flow rate adjustable.	2.8
	302 with bayonet- quick-release system	45° 60° 80° 90° 130°	0.40 – 3.15	Assembly with bayonet quick-release system.	Humidification of air in air washers, dust control, spraying onto filters, foam control, cooling. Quick and safe assembly with the aid of a bayonet quick-lock system. Automatic setting of spray plane. A time-saving alternative to threaded nozzle designs.	2.10
	350	130°	0.63 – 3.15	3/8 BSPP or quick-lock	Humidification of air in air washers, dust control, spraying onto filters, foam control. Extremely fine atomization with a narrow droplet distribution.	2.11
	304 306 307	90° 130°	5.60 – 33.50	1/2 BSPP 3/4 BSPP	Fire fighting, protection of storage tanks, foam control. Non-clogging nozzle design, without swirl insert.	2.12
	373 „Ramp Bottom“	70° 80° 90°	63.00 – 227.00	1 BSPP 1 1/4 BSPP 1 1/2 BSPP	Cooling and cleaning of gas, dust control, water recooling, chemical process engineering. Longer service life thanks to the patented »ramp bottom« design of the mixing chamber.	2.13
	309	90°	118.00 – 160.00	1 1/4 BSPP	Less expensive design in plastic material.	



Axial-flow hollow cone nozzles

Series 212

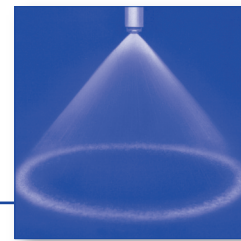

Extremely fine, fog-like hollow cone spray.

Applications:
Disinfection, humidification of air, spraying over germinating boxes, product humidification, humidification of textiles, spraying of oil, absorption.

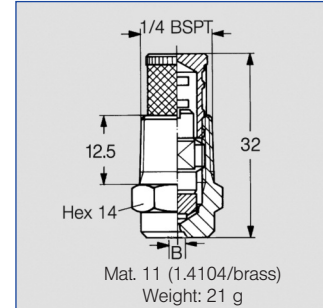
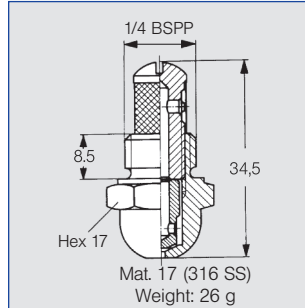

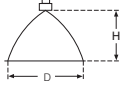
Spray angle	Ordering no.				B Ø [mm]	E Ø [mm]	\dot{V} [l/min]						Spray diameter D at p=7 bar  H = 100 mm	
	Type	Mat. no.		Code			p [bar]							
		11 AISI 430F/Brass	17 AISI 316Ti					2.0	3.0	5.0	7.0	10.0		20.0
60°	212.004	-	○	AC	-	0.10	0.10	-	-	0.013	0.015	0.018	0.025	80
	212.014	-	○	AC	-	0.15	0.15	-	-	0.019	0.023	0.027	0.039	80
	212.054	-	○	AC	-	0.20	0.15	-	-	0.027	0.033	0.039	0.057	80
80°	212.085	○*	○**	-	CC	0.25	0.25	-	-	0.040	0.047	0.057	0.080	140
	212.125	○*	○**	AC	CC	0.35	0.25	-	0.048	0.062	0.073	0.088	0.124	140
	212.145	○	-	-	CC	0.40	0.30	-	0.063	0.082	0.097	0.116	0.164	140
	212.165	○	-	-	CC	0.45	0.30	-	0.080	0.103	0.122	0.146	0.206	140
	212.185	○	-	-	CC	0.50	0.35	-	0.101	0.130	0.154	0.184	0.260	140
	212.205	○	-	-	CC	0.60	0.35	0.107	0.131	0.168	0.199	0.238	0.336	140
	212.245	○	-	-	CC	0.70	0.45	0.166	0.202	0.261	0.310	0.370	0.522	140
	212.285	○*	○**	AC	CC	0.90	0.60	0.262	0.320	0.390	0.460	0.550	0.770	140

B = bore diameter · E = narrowest free cross section

*Only available with code CC

**Only available with code AC

The integrated strainer avoids clogging of the nozzle and increases its service life.

Example for ordering: Type + Material-No. + Code = Ordering no.
212.004 + 17 + AC = 212.004.17.AC

Materials			
Material no.	Nozzle	Strainer holder	Strainer
11	AISI 430F	Messing	Monel
17	AISI 316Ti	AISI 316Ti	AISI 316Ti

The folded page at the end of the catalogue will give you a survey on the various assembly possibilities.

For complete assembly accessories, please refer to

»Accessories«.

Conversion formula for the above series: $\dot{V}_2 = \dot{V}_1 \cdot \sqrt{\frac{p_2}{p_1}}$





Axial-flow hollow cone nozzles

Series 214 / 216

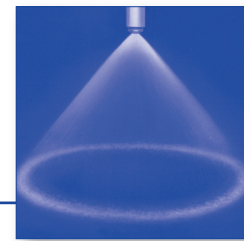

Fine, uniform hollow cone spray.

Applications:
Cooling and cleaning of air and gas, dust control, spraying onto filters, spray drying, desuperheating.

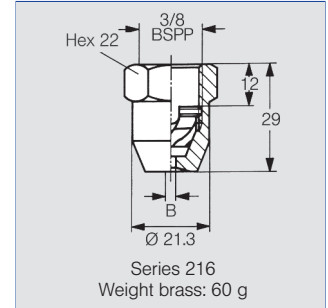
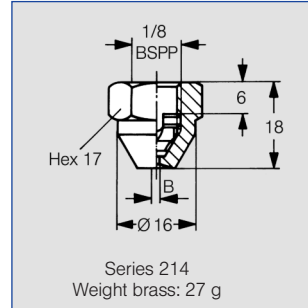

Spray angle	Ordering no.		G	B Ø [mm]	E Ø [mm]	V̇ [l/min]							Spray diameter D at p=3 bar H = 250 mm					
	Type	Mat. no.				p [bar]												
						17	30	0.5	1.0	2.0	3.0	5.0		10.0	20.0			
60°	214. 184	○ ○	1/8"	0.50	0.50	-	-	0.08	0.10	0.13	0.18	0.25	200					
						○ ○	1/8"	1.80	0.50	-	0.23	0.32		0.39	0.51	0.72	1.01	450
60°	216. 324	○ ○	3/8"	1.00	1.00	-	0.28	0.40	0.49	0.63	0.89	1.26	200					
						○ ○	3/8"	1.40	1.40	-	0.45	0.63		0.77	1.00	1.41	1.99	200
						○ ○	3/8"	2.00	2.00	-	0.71	1.00		1.22	1.58	2.24	3.16	200
90°	216. 496	○ ○	3/8"	3.00	2.00	-	1.20	1.70	2.08	2.69	3.80	5.38	500					
						○ ○	3/8"	4.00	2.00	-	1.77	2.50		3.06	3.95	5.59	7.91	500
						○ ○	3/8"	3.50	2.00	2.00	2.83	4.00		4.90	6.32	8.94	12.65	500
						○ ○	3/8"	4.00	2.00	2.50	3.54	5.00		6.12	7.91	11.18	15.81	500
						○ ○	3/8"	5.00	2.00	3.15	4.45	6.30		7.72	9.96	14.09	19.92	500
	216. 776	○ ○	3/8"	6.00	2.00	4.30	6.00	8.50	10.40	13.40	19.00	26.90	500					

B = bore diameter · E = narrowest free cross section

Example for ordering	Type	+	Material no.	=	Ordering no.
	214. 184	+	17	=	214. 184. 17

The folded page at the end of the catalogue will give you a survey on the various assembly possibilities. For complete assembly accessories, please refer to »Accessories«.



Axial-flow hollow cone nozzles for retaining nut Series 2TR

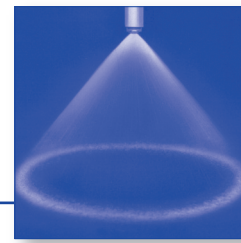

Hollow cone nozzle with ceramic insert. Assembly with retaining nut. Fine, uniform hollow cone spray.

Applications:
Humidification of air, cooling and cleaning of gases, dust control, spraying onto filters.

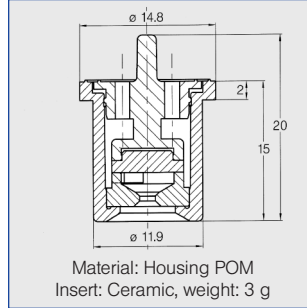
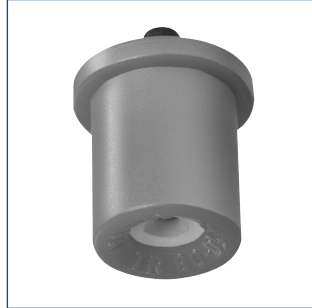

Spray angle	Ordering no.	Colour	B Ø [mm]	E Ø [mm]	\dot{V} [l/min]						Spray diameter D at p=3 bar H = 250 mm
	Type				p [bar] [p _{max} = 20 bar]						
					1.0	2.0	3.0	5.0	7.0	10.0	
80°	2TR. 245. C8	lilac	0.65	0.55	-	0.16	0.20	0.25	0.30	0.36	450
	2TR. 275. C8	black	0.80	0.70	0.16	0.22	0.27	0.35	0.41	0.49	450
	2TR. 305. C6	orange	0.90	0.80	0.23	0.32	0.39	0.51	0.60	0.72	450
	2TR. 345. C6	green	1.10	0.90	0.34	0.48	0.59	0.76	0.90	1.07	450
	2TR. 365. C6	yellow	1.40	0.95	0.45	0.63	0.78	1.01	1.19	1.42	450
	2TR. 405. C6	blue	1.70	1.10	0.68	0.96	1.17	1.52	1.79	2.14	450
	2TR. 445. C6	red	2.00	1.20	0.89	1.26	1.55	2.02	2.37	2.83	450
	2TR. 485. C6	brown	2.20	1.30	1.11	1.57	1.94	2.50	2.96	3.54	450

B = bore diameter · E = narrowest free cross section

The folded page at the end of the catalogue will give you a survey on the various assembly possibilities. For complete assembly accessories, please refer to »Accessories«.

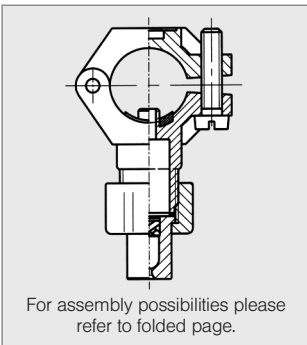

Conversion formula for the above series: $\dot{V}_2 = \dot{V}_1 \cdot \sqrt{\frac{p_2}{p_1}}$



Tangential-flow hollow cone nozzles

Brass versions

Series 302 / 308

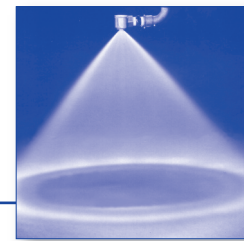

Uniform hollow cone spray. Non-clogging nozzle, with- out swirl insert.

Applications:

Humidification of air in air washers, dust control, spraying onto filters, foam control, cooling.

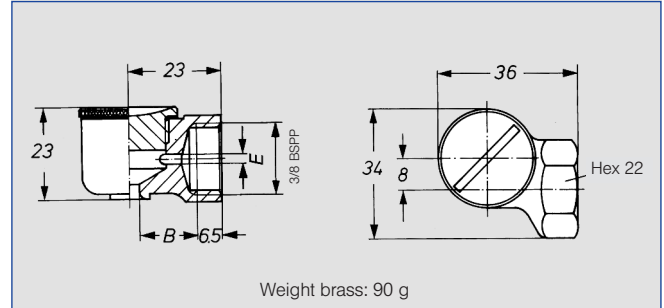

Spray angle	Ordering no.		B ∅ [mm]	E ∅ [mm]	\dot{V} [l/min]								Spray diameter D at p=2 bar	
	Type	Mat. no.			p [bar]								H =	
					30	1Y	0.5	1.0	2.0	3.0	5.0	7.0	10.0	250 mm
			Brass	AISI 316L										
60°	302. 364	○	-	1.50	1.50	0.31	0.45	0.63	0.77	1.00	1.18	1.41	200	350
	302. 464	○	○	2.00	2.00	0.70	0.99	1.40	1.71	2.21	2.62	3.13	300	560
80°	302. 545	○	○	4.90	2.30	1.12	1.58	2.24	2.74	3.54	4.19	5.01	400	700
90°	302. 606	○	○	4.60	4.00	1.57	2.23	3.15	3.86	4.98	5.89	7.04	450	750
130°	302. 368	○	○	3.00	1.00	0.31	0.45	0.63	0.77	1.00	1.18	1.41	800	1500
	302. 468	○	○	5.00	1.70	0.70	0.99	1.40	1.71	2.21	2.62	3.13	800	1500
	302. 548	○	-	5.00	2.50	1.12	1.58	2.24	2.74	3.54	4.19	5.01	800	1500
	302. 608	○	○	5.00	3.50	1.57	2.23	3.15	3.86	4.98	5.89	7.04	1000	1800
	302. 668	○	-	7.50	3.60	2.25	3.18	4.50	5.51	7.12	8.42	10.06	1200	2000
	302. 748	○	-	7.50	4.80	3.55	5.02	7.10	8.70	11.23	13.28	15.88	1200	2000

B = bore diameter · E = narrowest free cross section

Flow rate adjustable. Decrease in flow rate causes narrower spray angle.

Applications:

Dust control, foam control.

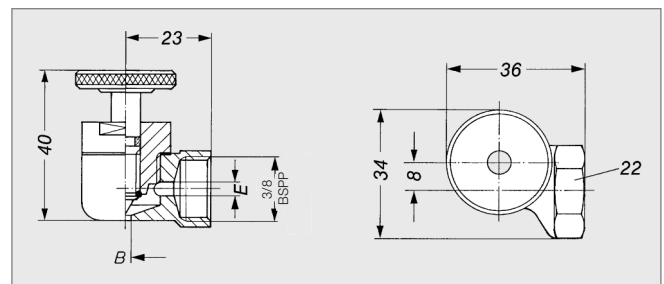

Spray angle	Ordering no.		B ∅ [mm]	E ∅ [mm]	\dot{V}_{max} [l/min]						Spray diameter D at p=2 bar		
	Type	Mat.- Nr.			p [bar]						H =		
					30	0.3	0.5	1.0	2.0	5.0	10.0	250 mm	500 mm
			Brass										
90°	308. 466	○	2.0	2.0	0.54	0.70	1.00	1.40	2.21	3.13	400	880	
	308. 606	○	4.0	4.0	1.22	1.58	2.23	3.15	4.98	7.04	450	950	

B = bore diameter · E = narrowest free cross section

Example	Type	+	Material no.	=	Ordering no.
for ordering	308. 466	+	30	=	308. 466. 30





Tangential-flow hollow cone nozzles

Plastic version

Series 302

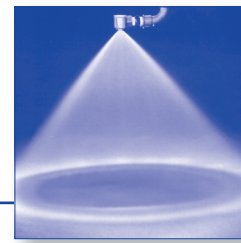

Uniform hollow cone spray. Non-clogging nozzle, with- out swirl insert.

Applications:

Humidification of air in air washers, dust control, spraying onto filters, foam control, cooling.

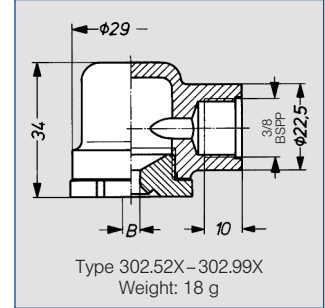
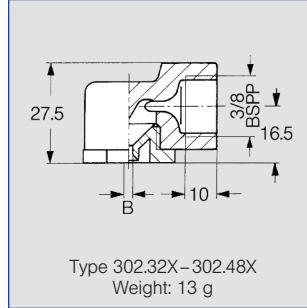

Spray angle	Ordering no.			B Ø [mm]	E Ø [mm]	V̇ [l/min]							Spray diameter D at p=2 bar		
	Type	Mat. no.				p [bar]							D	H	
		5E	51			53	0.5	1.0	2.0	[US gal./min] at 40 psi	3.0	5.0			10.0
		PVDF	PA	PP											
60°	302. 364	-	○	○	1.50	1.50	0.31	0.45	0.63	0.20	0.77	1.00	1.41	200	350
	302. 464	-	○	○	3.80	1.95	0.70	0.99	1.40	0.43	1.71	2.21	3.13	300	560
90°	302. 326	○	○	-	1.20	0.90	0.20	0.28	0.40	0.12	0.49	0.63	0.89	400	700
	302. 366	○	○	-	2.10	1.30	0.31	0.45	0.63	0.20	0.77	1.00	1.41	400	880
	302. 406	○	○	○	2.60	1.40	0.50	0.71	1.00	0.31	1.22	1.58	2.24	400	880
	302. 486	-	○	○	2.60	2.60	0.80	1.13	1.60	0.50	1.96	2.53	3.58	400	880
	302. 526	-	○	○	5.00	2.00	1.00	1.41	2.00	0.62	2.45	3.16	4.47	400	880
	302. 566	-	○	○	5.00	2.40	1.25	1.77	2.50	0.78	3.06	3.95	5.59	400	880
	302. 606	-	○	○	5.00	3.20	1.57	2.23	3.15	0.98	3.86	4.98	7.04	450	950
	302. 686	-	○	-	7.50	3.40	2.50	3.45	5.00	1.55	6.12	7.91	11.18	500	1050
	302. 766	-	○	-	9.00	4.30	4.00	5.66	8.00	2.48	9.80	12.65	17.89	500	1050
	302. 846	-	○	○	11.00	5.20	6.25	8.84	12.50	3.88	15.31	19.67	27.95	550	1130
130°	302. 328	○	-	-	1.35	0.80	0.20	0.28	0.40	0.12	0.49	0.63	0.89	700	1380
	302. 368	○	○	-	1.85	1.10	0.31	0.45	0.63	0.20	0.77	1.00	1.41	700	1380
	302. 408	○	○	-	3.65	1.30	0.50	0.71	1.00	0.31	1.22	1.58	2.24	700	1380
	302. 488	-	○	○	5.20	1.60	0.80	1.13	1.60	0.50	1.96	2.53	3.58	700	1380
	302. 528	-	○	-	5.00	2.00	1.00	1.41	2.00	0.62	2.45	3.16	4.47	700	1380
	302. 568	-	○	-	5.00	2.40	1.25	1.77	2.50	0.78	3.06	3.95	5.59	780	1520
	302. 608	○	○	○	5.00	3.20	1.57	2.23	3.15	0.98	3.86	4.98	7.04	780	1520
	302. 648	-	○	-	7.50	3.00	2.00	2.83	4.00	1.20	4.90	6.32	8.94	950	1850
	302. 688	-	○	-	7.50	3.40	2.50	3.54	5.00	1.55	6.12	7.91	11.18	950	1850
	302. 728	-	○	-	7.50	4.10	3.15	4.45	6.30	1.89	7.72	9.96	14.09	950	1850
302. 768	-	○	-	9.00	4.30	4.00	5.66	8.00	2.48	9.80	12.65	17.89	950	1850	
302. 848	-	○	-	11.00	5.20	6.25	8.84	12.50	3.88	15.31	19.76	27.95	950	1850	
302. 888	-	○	○	11.00	6.40	8.00	11.31	16.00	4.96	19.60	25.30	35.78	950	1850	
302. 968	○	○	-	11.00	8.60	12.50	17.68	25.00	7.75	30.62	39.53	55.90	950	1850	

B = bore diameter · E = narrowest free cross section

The folded page at the end of the catalogue will give you a survey on the various assembly possibilities.
For complete assembly accessories, please refer to »Accessories«.

Example for ordering	Type	+	Material no.	=	Ordering no.
	302. 364	+	51	=	302. 364. 51

Conversion formula for the above series: $\dot{V}_2 = \dot{V}_1 * \sqrt{\frac{p_2}{p_1}}$





Tangential-flow hollow cone nozzles

Bayonet quick-release system

Series 302

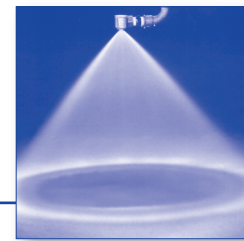

A time-saving alternative to threaded design. Quick and secure assembling. Automatic setting of spray direction.

Applications:
Humidification of air in air washers, dust control, spraying onto filters, foam control.

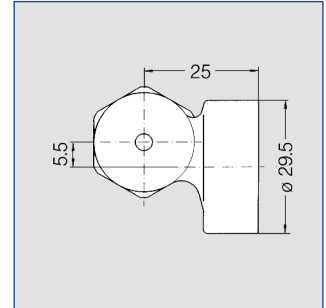
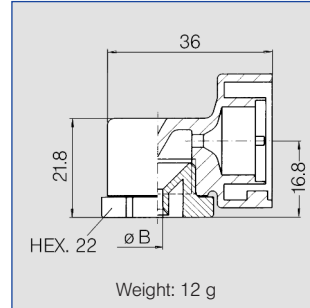

Spray angle	Ordering no.				B \varnothing [mm]	E \varnothing [mm]	\dot{V} [l/min]						Spray diameter D at p=2 bar		
	Type	Mat. no.		Code			p [bar]								
		51	56				0.5	1.0	2.0	US [gal/min] at 40 psi	3.0	4.0			10.0
45°	302. 503	○	-	KB	2.05	2.05	0.90	1.27	1.80	0.56	2.20	2.85	4.02	220	560
	302. 464	-	○	KB	1.95	1.95	0.70	0.99	1.40	0.43	1.71	2.21	3.13	300	560
80°	302. 545	-	○	KB	2.30	2.30	1.12	1.58	2.24	0.69	2.74	3.54	5.01	400	700
90°	302. 326	○	○	KB	1.05	1.05	0.20	0.28	0.40	0.12	0.49	0.63	0.89	400	700
	302. 406	○	○	KB	1.55	1.55	0.50	0.71	1.00	0.31	1.22	1.58	2.24	400	880
	302. 486	○	-	KB	2.10	2.10	0.80	1.13	1.60	0.50	1.96	2.53	3.58	400	880
	302. 606	○	-	KB	5.00	3.20	1.58	2.23	3.15	0.98	3.86	4.98	7.04	450	880
130°	302. 368	-	○	KB	1.30	1.30	0.31	0.45	0.63	0.20	0.77	1.00	1.41	700	1380
	302. 408	○	○	KB	2.00	2.00	0.50	0.71	1.00	0.31	1.22	1.58	2.24	700	1380
	302. 468	○	-	KB	2.40	2.40	0.70	0.99	1.40	0.43	1.71	2.21	3.13	700	1380
	302. 488	○	-	KB	2.75	2.75	0.80	1.13	1.60	0.50	1.96	2.53	3.58	700	1380

B = bore diameter · E = narrowest free cross section

Example Type + Material no. + Code = Ordering no.
for ordering: 302. 503 + 51 + KB = 302. 503. 51. KB

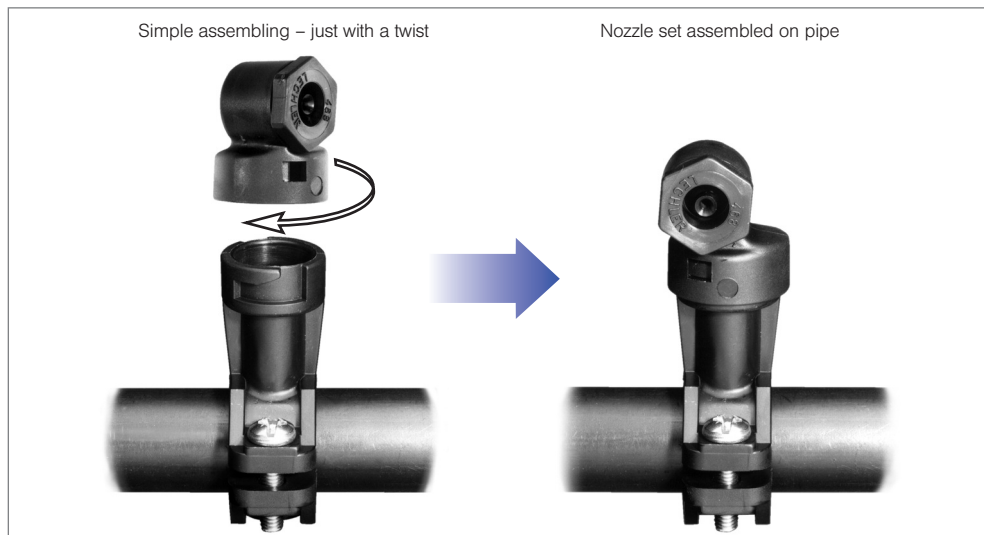

The folded page at the end of the catalogue will give you a survey on the various assembly possibilities. For complete assembly accessories, please refer to »Accessories«.



Tangential-flow hollow cone nozzles

Series 350

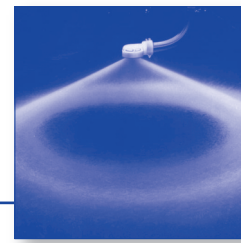

High-performance eccentric spray nozzles for air-conditioning. Narrow drop spectrum and extremely uniform distribution of liquid over the entire spray pattern.

Applications:

Humidification of air in air washers, dust control, spraying onto filters, foam control.

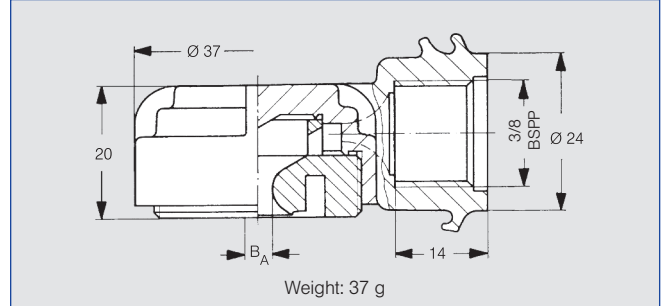

Spray angle	Ordering no.		B Ø [mm]	E Ø [mm]	\dot{V} [l/min]							Spray diameter D at p=2 bar		
	Type	Mat.- Nr. 56			p [bar]							p _{max} : 20 bar		
					0.5	1.0	2.0	3.0	5.0	7.0	10.0	H = 250 mm	H = 500 mm	
130°	350. 368	○	1.55	0.70	0.32	0.45	0.63	0.77	1.00	1.18	1.41	1120	2000	
	350. 608	○	5.00	1.40	1.58	2.23	3.15	3.86	4.98	5.89	7.04	1140	2100	

B = bore diameter · E = narrowest free cross section

Example	Type	+	Material no.	=	Ordering no.
for ordering:	350. 368	+	56	=	350. 368. 56

Accessories

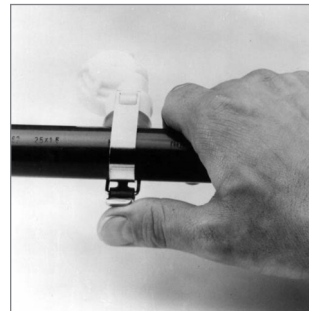
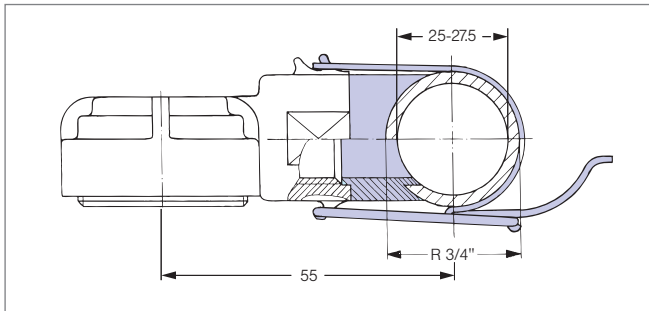

Quick snap clamp unit · **Ord.-no.: 035. 030. 15. 05. 00. 0**
consisting of: Stainless steel clamp and polyurethan gasket

Bore-Ø: 18 mm

Conversion formula for the above series: $\dot{V}_2 = \dot{V}_1 * \sqrt{\frac{p_2}{p_1}}$





Tangential-flow hollow cone nozzles

Series 304 / 306 / 307

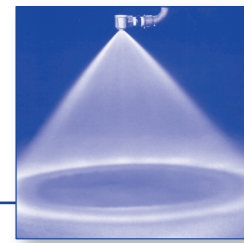

Uniform hollow cone spray.
Non-clogging nozzle,
without swirl insert.
 Applications:
 Fire fighting, protection of
 storage tanks, foam control.

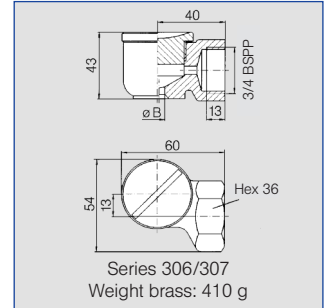
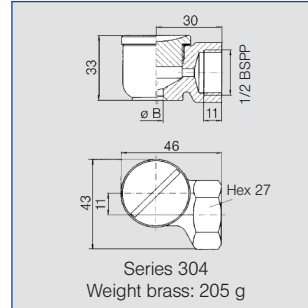

Spray angle	Ordering no.		G	B ∅ [mm]	E ∅ [mm]	V̇ [l/min]								Spray diameter D at p=2 bar	
	Type	Mat. no.				p [bar]								H =	
						30	1Y	0.5	1.0	2.0	3.0	5.0	7.0	10.0	250 mm
			BSPP												
90°	304. 706	○	○	1/2"	5.10	5.10	2.80	3.96	5.60	6.86	8.85	10.47	12.52	450	750
	304. 796	○	○	1/2"	8.90	6.00	4.75	6.72	9.50	11.64	15.02	17.77	21.24	450	750
	306. 906	○	○	3/4"	9.00	9.00	9.00	12.73	18.00	22.05	28.46	33.68	40.25	470	850
	306. 976	○	○	3/4"	13.50	10.00	13.25	18.74	26.50	32.46	41.90	49.58	59.26	470	850
130°	304. 818	○	-	1/2"	12.00	5.00	5.30	7.50	10.60	12.98	16.76	19.83	23.70	1400	1800
	304. 898	○	○	1/2"	12.00	7.00	8.50	12.02	17.00	20.82	26.88	31.80	38.01	1400	1800
	306. 978	○	-	3/4"	19.00	7.30	13.25	18.74	26.50	32.46	41.90	49.58	59.25	1450	2400
	307. 018	○	○	3/4"	19.00	8.60	16.75	23.69	33.50	41.03	52.97	62.67	74.91	1450	2400

B = bore diameter · E = narrowest free cross section

Example	Type	+	Material no.	=	Ordering no.
for ordering:	304. 706	+	30	=	304. 706. 30

The folded page at the end of the catalogue will give you a survey on the various assembly possibilities. For complete assembly accessories, please refer to »Accessories«.

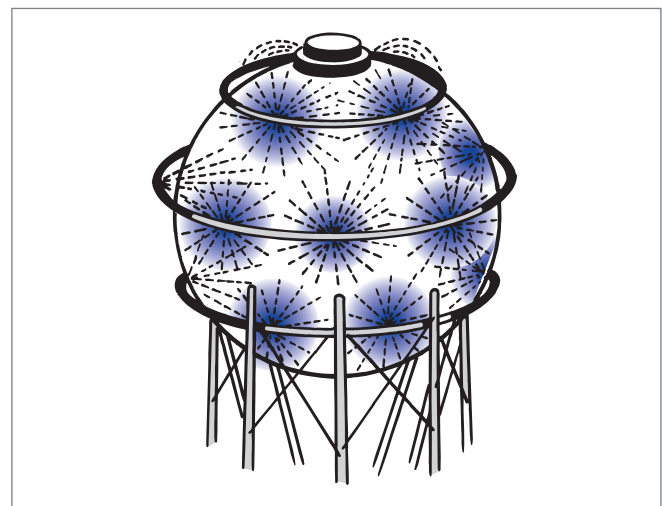

Fire protection on spherical storage tank.

For further informations please ask for our brochure about fire protection.



Tangential-flow hollow cone nozzles

Series 373 »Ramp Bottom« / 309



Fine, uniform hollow cone spray, also at low pressures.

Applications:

cooling and cleaning of gas, water re-cooling, dust control, chemical process engineering.



Sectional view of a series 373 »Ramp Bottom« nozzle

»Ramp Bottom« design offering a longer service life, due to the patented »sloping« shape of the swirl chamber.

Dimensions

BSPP	L [mm]	D [mm]	H [mm]	E [mm]	SW	Weight 316 SS [g]
1	67	45	52	6.3	41	285
1 1/4	77	51	65	7.9	48	570
1 1/2	97	65	81	7.9	58	900

Series 373 „Ramp Bottom“

Less expensive plastic version, with low requirements on temperature and abrasion resistance.

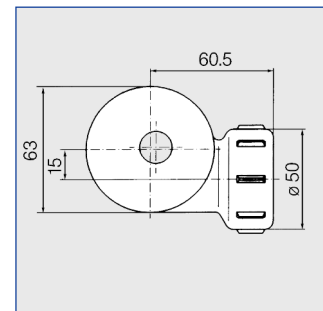
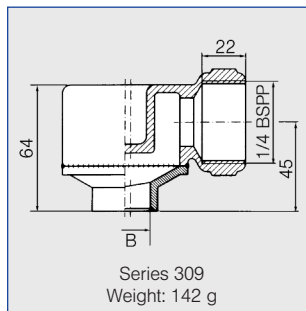

Spray angle	Ordering no.					B ∅ [mm]	\dot{V} [l/min]						Spray diameter D at p=2 bar	
	Type	Mat. no.	Code				p [bar]							
			AISI 316Ti	1 BSPP	1 1/4 BSPP		1 1/2 BSPP	0.3	0.5	1.0	2.0	5.0		
70°	373. 115	○	AN	-	-	11.40	24.40	31.50	44.50	63.00	99.60	141.00	650	1300
80°	373. 175	○	AN	-	-	12.90	31.00	40.00	56.60	80.00	126.00	179.00	800	1550
	373. 235	○	-	AQ	-	16.20	45.70	59.00	83.40	118.00	187.00	264.00	700	1350
	373. 285	○	-	AQ	-	20.50	62.00	80.00	113.00	160.00	253.00	358.00	800	1550
	373. 325	○	-	-	AS	22.20	77.50	100.00	141.00	200.00	316.00	447.00	800	1550
	373. 365	○	-	-	AS	23.60	67.90	114.00	161.00	227.00	359.00	508.00	700	1400

Plastic version:

90°	309. 236. 5E	(Material PVDF)	20.00	45.70	59.00	83.40	118.00	187.00	264.00	850	1500
	309. 286. 5E	(Material PVDF)	24.00	62.00	80.00	113.00	160.00	253.00	358.00	750	1400

B = bore diameter

Example for ordering Type + Material no. + Code = Ordering no.
 373. 115 + 17 + AN = 373. 115. 17. AN

Conversion formula for the above series: $\dot{V}_2 = \dot{V}_1 * \sqrt{\frac{p_2}{p_1}}$



